

Centre No.						Paper Reference					Surname	Initial(s)	
Candidate No.						4	4	2	0	/	2	H	Signature

Paper Reference(s)

**4420/2H**

**London Examinations IGCSE**

**Physics**

**Paper 2H**

**Higher Tier**

Monday 8 June 2009 – Morning

Time: 2 hours

Examiner's use only

--	--	--

Team Leader's use only

--	--	--

**Materials required for examination**

Nil

**Items included with question papers**

Nil

Question Number	Leave Blank
1	
2	
3	
4	
5	
6	
7	
8	
9	
10	
11	
12	
13	
14	
15	
16	
17	
18	
19	
Total	

**Instructions to Candidates**

In the boxes above, write your centre number, candidate number, your surname, initial(s) and signature.  
 The paper reference is shown at the top of this page. Check that you have the correct question paper.  
 Answer **ALL** the questions. Write your answers in the spaces provided in this question paper.  
 Show all the steps in any calculations and state the units.  
 Calculators may be used.

**Information for Candidates**

The total mark for this paper is 120. The marks for individual questions and the parts of questions are shown in round brackets: e.g. (2). There are 19 questions in this question paper.  
 Any blank pages are indicated.  
 Useful formulae are given on page 2.

**Advice to Candidates**

Write your answers neatly and in good English.

This publication may be reproduced only in accordance with Edexcel Limited copyright policy. ©2009 Edexcel Limited.

Printer's Log. No.  
**N34027A**

W850/U4420/57570 5/7/7/3/



**Turn over**

**edexcel**  
advancing learning, changing lives

## FORMULAE

You may find the following formulae useful.

$$\text{power} = \frac{\text{work done}}{\text{time taken}}$$

$$P = \frac{W}{t}$$

$$\text{power} = \frac{\text{energy transferred}}{\text{time taken}}$$

$$P = \frac{W}{t}$$

$$\text{frequency} = \frac{1}{\text{time period}}$$

$$f = \frac{1}{T}$$

Where necessary, assume the acceleration of free fall,  $g = 10 \text{ m/s}^2$ .



1. (a) Graphs **A**, **B**, **C** and **D** show how the extension  $x$  changes with the applied force  $F$  for different objects.

Draw a line linking each object to its graph.

**Object**

**Graph**

helical spring

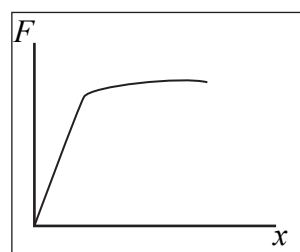

**A**

metal wire

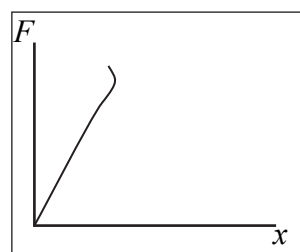

**B**

rubber band

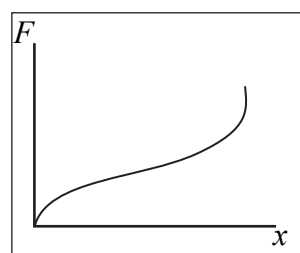

**C**

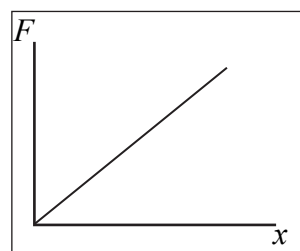

**D**

(3)

(b) (i) Complete the sentence.

An object obeys Hooke's Law when the ..... and the ..... are ..... proportional to each other.

(2)

(ii) Which of the graphs in (a) is for an object that obeys Hooke's Law throughout?

.....

(1)

**Q1**

(Total 6 marks)



2. A student ties one end of a rope to a chair. She uses the rope to demonstrate wave behaviour to her class.

(a) She produces a transverse wave as shown below. **A** is the direction of vibration and **B** is the direction of the wave.

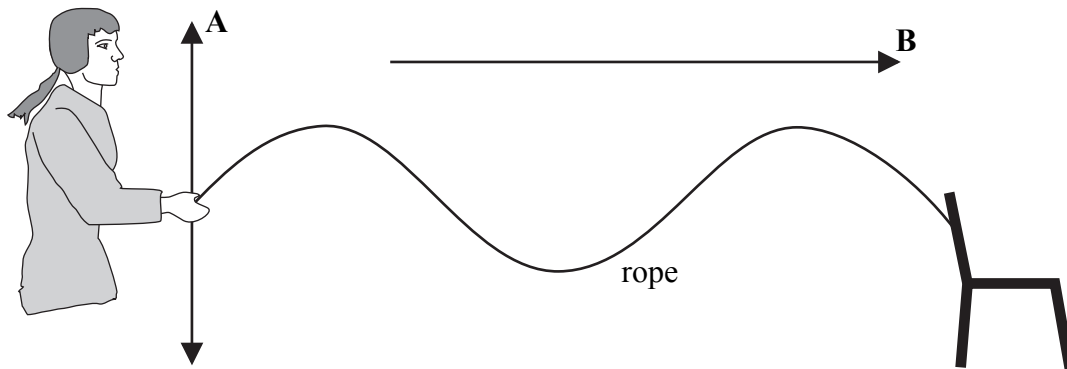

(i) State how the student could increase the amplitude of the wave.

.....  
.....

(1)

(ii) State how the student could decrease the wavelength to produce the wave shown below.

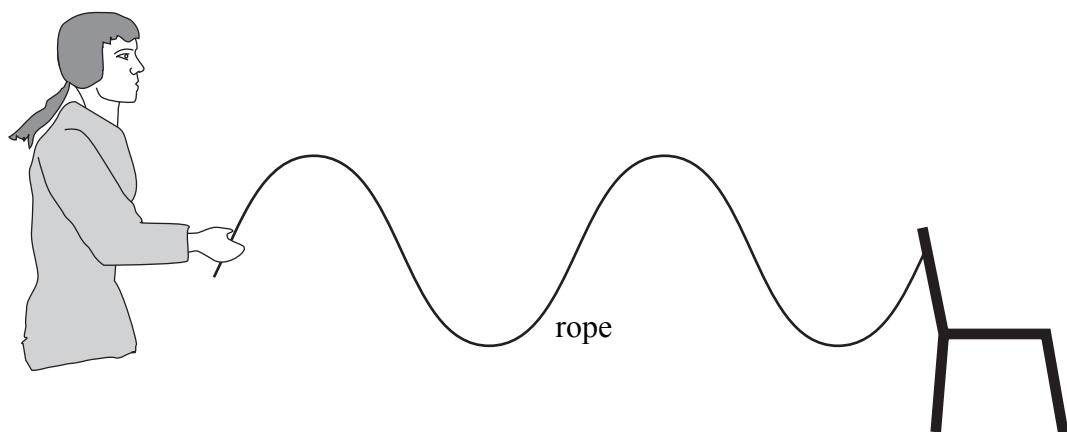

.....  
.....

(2)



Leave  
blank

(b) When the frequency of the wave is 1.5 Hz, the wavelength is 0.80 m. Calculate the speed in m/s of the wave.

.....  
.....

Speed = ..... m/s  
**(3)**

(c) The student then uses a spring to demonstrate the behaviour of a longitudinal wave.



Draw arrows on this diagram to show

- (i) the direction of vibration, and label this **A**.
- (ii) the direction of the wave, and label this **B**.

**(2)**

**Q2**

**(Total 8 marks)**



Leave blank

3. The first hot air balloon to cross the Pacific Ocean did so in 1991. It took 46 hours to travel 10 700 km.

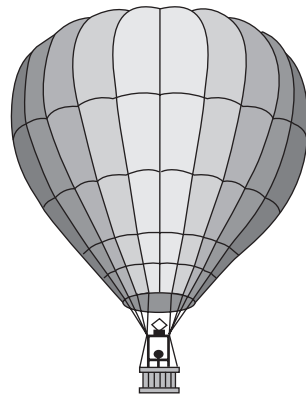

- (a) Choose words from the box to complete the sentences.  
Each word may be used once, more than once or not at all.

<b>conduction</b>	<b>contracts</b>	<b>convection</b>	<b>expands</b>
<b>increases</b>	<b>less</b>	<b>more</b>	<b>radiation</b>
			<b>reduces</b>

In a hot air balloon the air inside the balloon is heated.

The heated air ..... and becomes .....  
dense. Some of the air is pushed out of the balloon.

This ..... the mass of air in the balloon and the balloon  
rises. The hot air inside the balloon rises and hence transfers heat energy by a process  
known as ..... Two other processes of transferring heat  
energy are ..... and .....

(6)

- (b) A hot air balloon carries a mass of 3500 kg.

Calculate the weight in N of this mass.

.....

Weight = ..... N  
(2)

Q3

(Total 8 marks)



Leave  
blank

4. (a) Phosphorus-32 (P-32) is a radioactive isotope. It has a half-life of 14 days. It is used to treat some bone diseases. The activity of a sample of P-32 is 10 000 Bq.

(i) What is Bq an abbreviation of?

.....  
(1)

(ii) Calculate the activity, in Bq, of this sample after 28 days.

.....  
.....

Activity = ..... Bq  
(2)

(b) Another radioactive isotope of phosphorus, P-34, has a half-life of 12.4 seconds.

(i) State what is meant by the term **isotope**.

.....  
.....  
(2)

(ii) After 28 days, some activity is still detected close to a sample of P-34. What do we call this activity?

.....  
(1)

(c) State two non-medical uses of radioactivity.

1 .....

2 .....

(2) **Q4**

(Total 8 marks)



**BLANK PAGE**





5. A class uses a step-up transformer in a model transmission line. The transformer is shown below. The input voltage is 6 V a.c. and there are 20 primary turns.

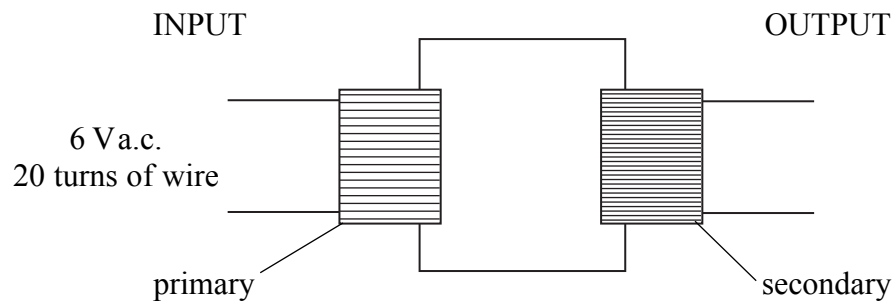

- (a) The output voltage is 24 V a.c. How many secondary turns does the transformer have?

.....  
.....

Number of turns = .....  
**(2)**

- (b) State how this transformer could be used as a step-down transformer.

.....  
.....

**(1)**

- (c) A student wants to use an input voltage of 60 V a.c. Why does the teacher tell him that this is not a good idea?

.....  
.....

**(1)**

- (d) A step-up transformer is used just outside a power station to increase the voltage. State why the voltage is increased.

.....  
.....

**(1)**

**(Total 5 marks)**

**Q5**



6. In electrostatic paint spraying, the surface being painted is given a negative charge. The paint emerges from the paint sprayer carrying a positive charge.

(a) The diagram shows a metal frame being painted.

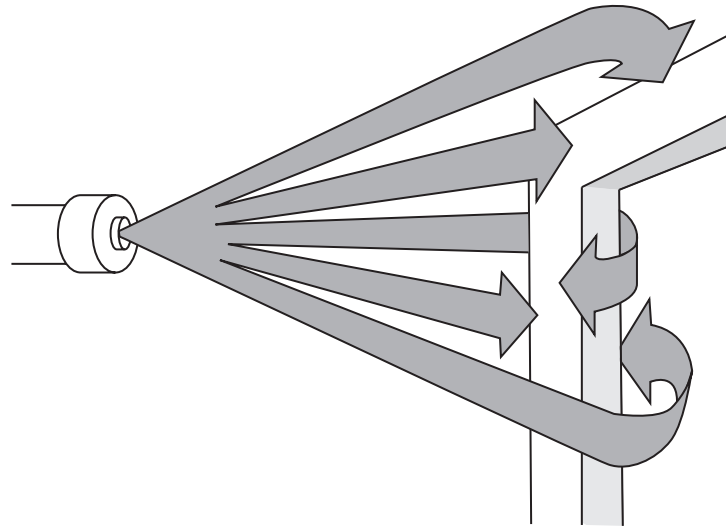

(i) Why is the paint attracted to the surface of the frame?

..... (1)

(ii) After one coat of this paint the paint is no longer attracted to the frame. Explain why this is.

..... (1)

(b) A feature of electrostatic paint spraying is that the back of the metal frame is painted. Explain why this happens.

..... (1)

(c) A disadvantage of electrostatic paint spraying is that many other things like walls get painted as well. Suggest how this can be avoided.

..... (1)





<p>(d) Name two other uses of electrostatic charges.</p> <p>1 .....</p> <p>2 .....</p> <p style="text-align: right;"><b>(2)</b></p> <p style="text-align: right;"><b>(Total 6 marks)</b></p>	Leave blank
	<p style="text-align: center;"><b>Q6</b></p> <input data-bbox="1612 795 1654 863" type="text"/>



N 3 4 0 2 7 A 0 1 1 3 6



Leave  
blank

7. (a) Particles in both a solid and a liquid are close-packed but the particles move in different ways.

State how the particles move

(i) in a solid,

.....  
.....  
(1)

(ii) in a liquid.

.....  
.....  
(1)

(b) State one difference in the arrangement of the particles in a gas compared to those in solids and liquids.

.....  
.....  
(1)

(c) Name a process by which a liquid changes to a gas.

.....  
(1)

(Total 4 marks)

Q7



Leave blank

8. The diagram shows the sizes of the two horizontal forces, X and Y, acting on a road tanker.

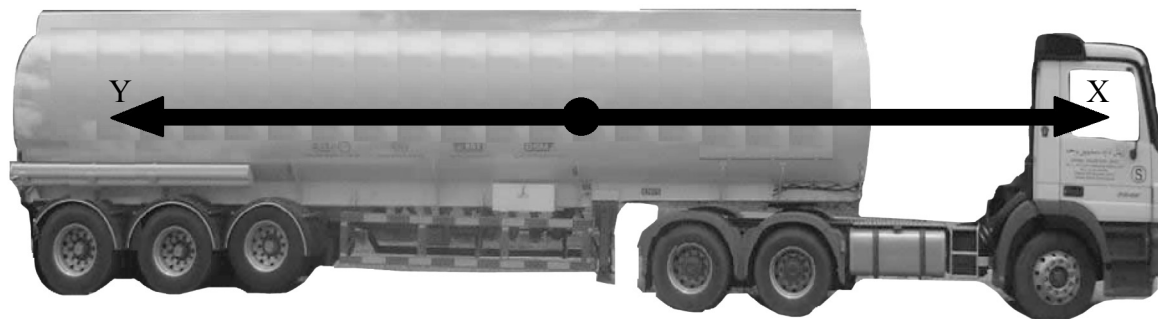

(a) Force is a vector quantity.  
What does this mean?

.....  
..... (1)

(b) The unbalanced force is sometimes called the resultant force.  
Complete the equation for the unbalanced force on the road tanker.

Unbalanced force = ..... (1)

(c) A student writes this list of quantities.

**acceleration    density    energy    mass    temperature    volume**

The student says they are all scalar quantities.

Do you agree with the student? Explain.

.....  
.....  
..... (2)

(Total 4 marks)

Q8



Leave blank

9. The diagram shows the magnetic field between magnetic poles X and Y.

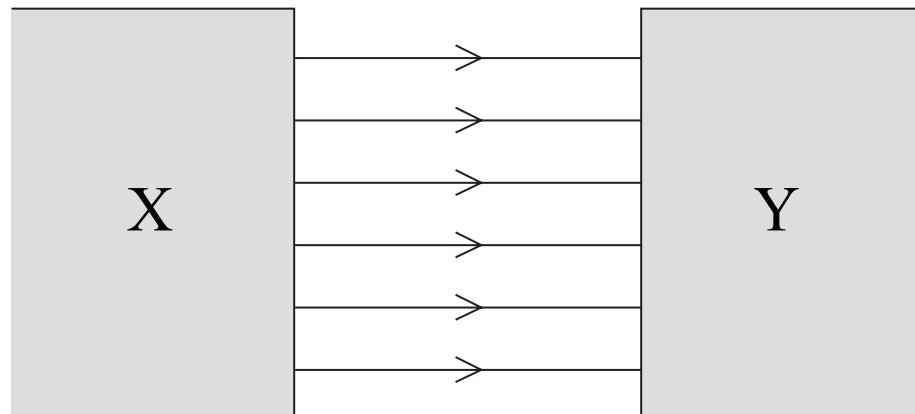

Use one word in each space to complete the sentences.

(a) The straight, parallel, evenly-spaced lines show that the magnetic field pattern between X and Y is ..... (1)

(b) X is a ..... pole and Y is a ..... pole. (1)

(c) A particle moves through the magnetic field. An electromagnetic force acts on this particle. This shows that the particle must be ..... and that its motion is not ..... to the magnetic field. (2)

(Total 4 marks)

Q9



Leave  
blank

10. (a) A deep-sea diver descends into deeper water. The pressure on him increases as the height of the water above him increases.

(i) State the equation which relates the density of the water, the acceleration of free fall,  $g$ , the height of the water above the diver and the pressure difference.

.....  
(1)

(ii) The diver descends from a depth of 15 m to a depth of 135 m.  
Calculate the increase in pressure and give the unit.  
The density of the water is  $1025 \text{ kg/m}^3$ .

.....  
.....  
Increase in pressure = .....  
(3)

(iii) The water is not moving. In which direction does the pressure act on the diver?

.....  
(1)

(b) A pressure is exerted on everyone on the Earth. Explain what causes this pressure.

.....  
.....  
.....  
(2)

(Total 7 marks)

Q10



11. The circuit diagram shows a metal filament lamp connected in series to a battery, a closed switch and a component X.

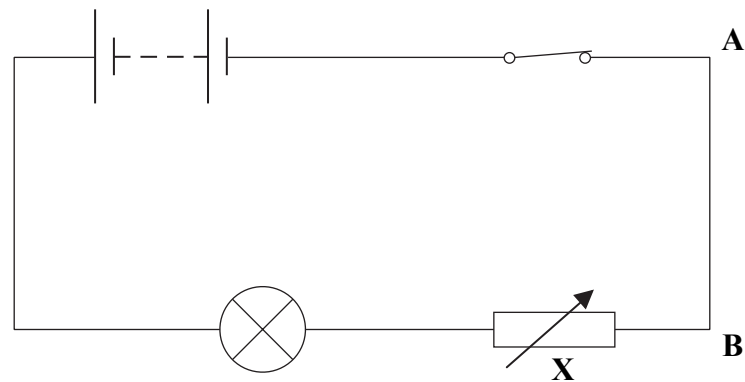

(a) What is component X?

..... (1)

(b) Adjusting component X alters the current in the lamp. Complete the sentence.

Current is the ..... of flow of ..... (1)

(c) Complete the table for the equation in the box by writing the unit name in full.

$$Q = I \times t$$

Abbreviation for quantity	Unit for quantity
<i>Q</i>	
<i>I</i>	
<i>t</i>	

(3)





<p>(d) (i) Name the particles which flow in the wire from <b>A</b> to <b>B</b>.</p> <p>.....</p> <p style="text-align: right;"><b>(1)</b></p> <p>(ii) Explain why they flow in this direction.</p> <p>.....</p> <p>.....</p> <p style="text-align: right;"><b>(1)</b></p> <p style="text-align: right;"><b>(Total 7 marks)</b></p>	<p>Leave blank</p> <p><b>Q11</b></p> <input data-bbox="1612 973 1654 1041" type="text"/>
--	--



Leave blank

12. The velocity–time graph shows a journey made by a train.

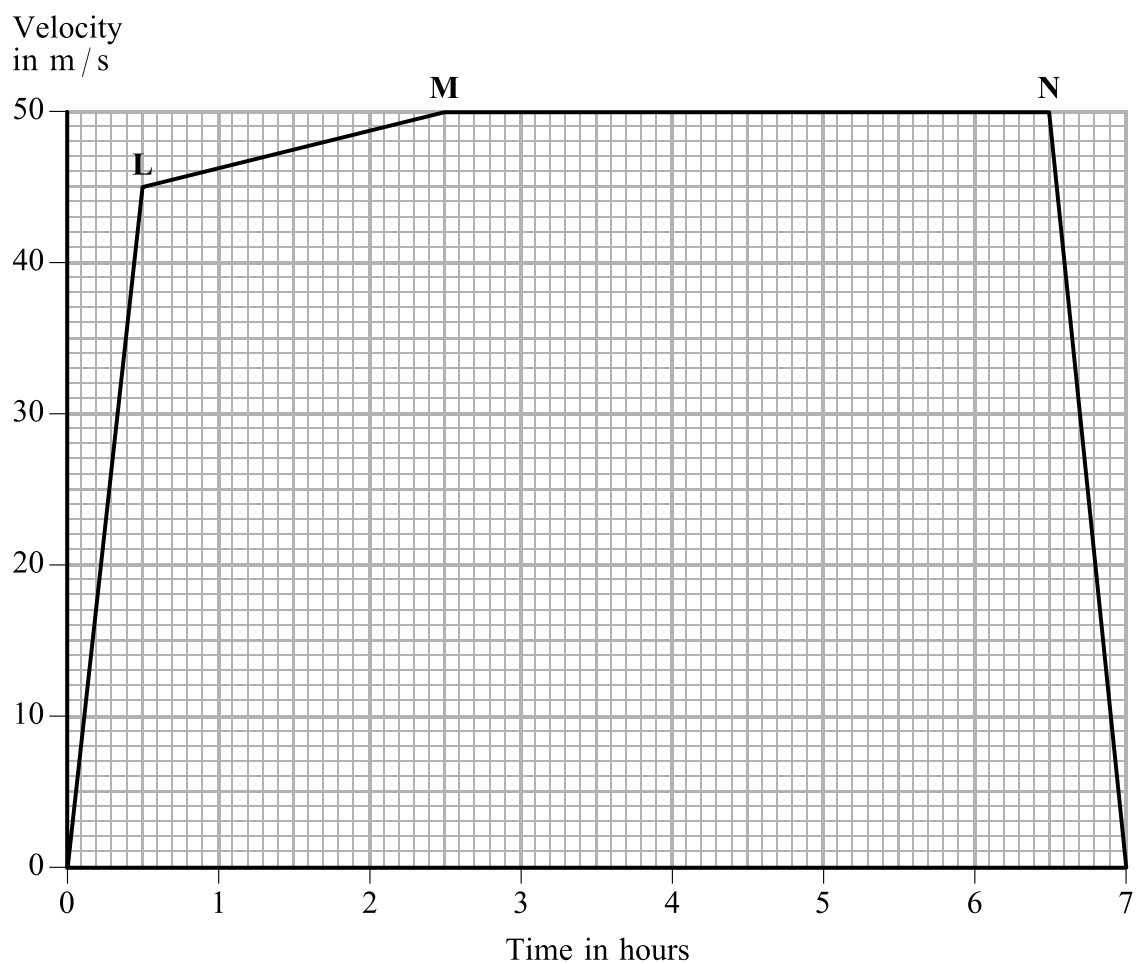

(a) (i) State the equation which relates acceleration, change in velocity and time taken.

.....  
.....  
(1)

(ii) Calculate the train's acceleration between the start and point L and give the unit.

.....  
.....  
Acceleration = .....  
(3)

(b) Describe the motion of the train in the section MN.

.....  
.....  
(2)



Leave  
blank

- (c) A student uses the graph to calculate the distance travelled by the train.  
She writes the equation shown in the box.

$$D = \frac{A \times 60 \times 60}{1000}$$

where  $A$  = area under the graph  
and  $D$  = distance travelled by the train

State the correct unit in this equation for  $D$ .

.....

(1)

Q12

(Total 7 marks)



13. The diagram shows the forces which act on a coconut as it falls from a tall palm tree. There is no wind.

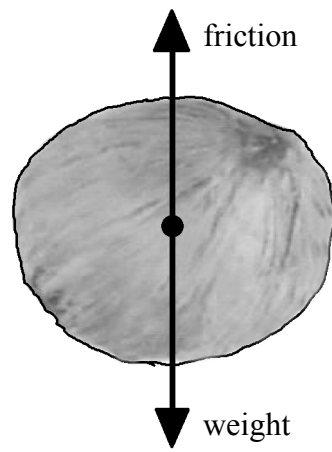

(a) (i) Explain in terms of the forces involved why, at first, the coconut accelerates.

.....  
.....  
**(1)**

(ii) Name the friction force which acts on the coconut as it falls.

.....  
**(1)**

(iii) What happens to the friction force as the coconut accelerates?

.....  
**(1)**

(iv) Name the term used for the downwards speed of the coconut when the friction force equals the coconut's weight.

.....  
**(1)**



Leave  
blank

(b) (i) State the equation which relates kinetic energy, mass and speed.

.....  
(1)

(ii) The mass of the coconut is 0.80 kg. Just before it hits the ground its kinetic energy is 32.4 J.

Calculate its speed just before it hits the ground and state the unit.

.....  
.....  
.....

Speed = .....  
(3)

Q13

(Total 8 marks)



**BLANK PAGE**



Leave blank

14. A gas-holder is designed so that it can change the volume and the pressure of the gas that it holds.



The pressure of the gas in the gas-holder is 250 kPa when its volume is 450 m<sup>3</sup>.

- (a) The volume is changed to 200 m<sup>3</sup>.  
Calculate the new pressure in kPa and give its value to the nearest 10 kPa.  
Show clearly how you get your answer.

.....  
.....

New pressure = ..... kPa  
**(3)**

- (b) State two assumptions which you made to answer part (a).

Assumption 1 .....

Assumption 2 .....

- (c) Name the unit for which kPa is the symbol.

.....  
**(1)**

**(Total 6 marks)**

**Q14**



15. A pile-driver is a machine used on building sites. It lifts a steel mass and then lets it drop. This drives a steel pile into the ground.

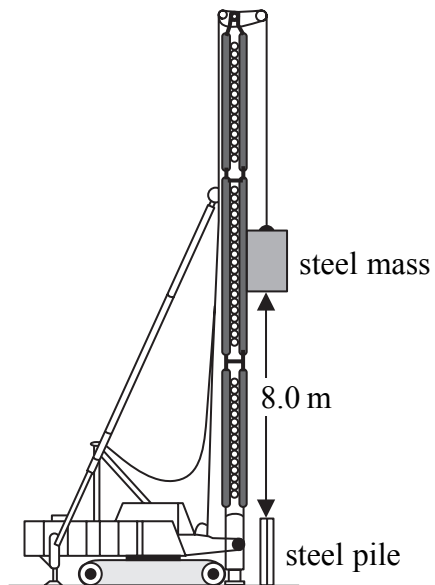

One pile-driver lifts a mass of 400 kg to a height of 8.0 m above the top of a steel pile.

- (a) (i) State the equation used to calculate gravitational potential energy (GPE).

.....  
**(1)**

- (ii) Calculate the increase in GPE, in joules, of the mass when it is lifted 8.0 m.

.....  
 .....

Increase in GPE = ..... J  
**(2)**

- (iii) What is the kinetic energy (KE), in joules, of the falling mass just before it hits the top of the steel pile?

KE = ..... J  
**(1)**





Leave blank

(b) The falling mass is brought to a stop very quickly when it hits the top of the steel pile.

(i) Explain why this shows that the falling mass has experienced a large force.

.....  
.....  
.....  
.....

(3)

(ii) In which direction did this force act on the falling mass?

.....

(1)

Q15

(Total 8 marks)



**BLANK PAGE**



Leave  
blank

16. (a) Complete the sentence.

There is an absolute zero of temperature which is ..... degrees Celsius  
or ..... kelvin.

(1)

(b) State the effect that increasing the kelvin temperature has on

(i) the average speed of the molecules of gas in a sealed container

.....  
(1)

(ii) the pressure of the gas in a sealed container.

.....  
(1)

(c) State the effect on the average kinetic energy of the molecules of gas when the kelvin  
temperature is doubled.

.....  
(1)

Q16

(Total 4 marks)

27

Turn over



17. (a) Complete the sentence.

A current in a conductor produces a .....  
around the conductor.

(1)

(b) The diagram shows a current-carrying wire in a magnetic field.

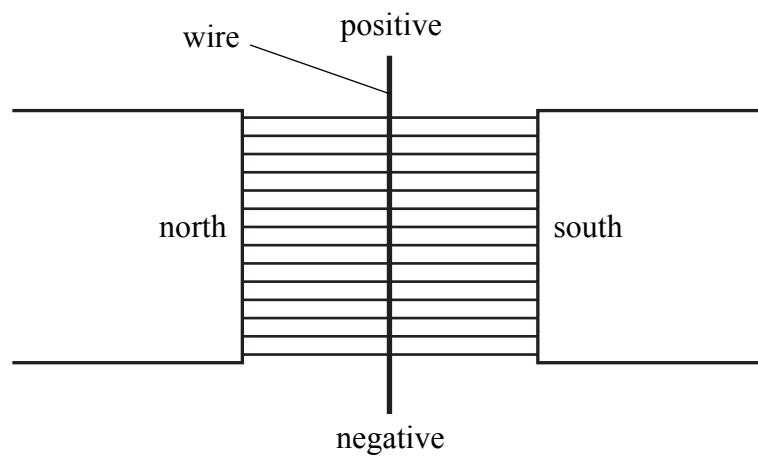

The wire is free to move.  
A student correctly predicts that when the current is switched on the wire will move out of the page.  
Name the rule the student used to make her prediction and explain how she used the rule.  
You may draw a diagram to help to explain your answer.

.....  
.....  
.....  
.....

(3)





<p>(c) Give one way to increase the electromagnetic force on a wire in a magnetic field.</p> <p>.....</p> <p>.....</p> <p style="text-align: right;"><b>(1)</b></p> <p>(d) A device uses the changing electromagnetic force on a coil of wire in a magnetic field to make a cone vibrate.</p> <p>Name this device.</p> <p>.....</p> <p style="text-align: right;"><b>(1)</b></p> <p style="text-align: right;"><b>(Total 6 marks)</b></p>	<p>Leave blank</p> <p><b>Q17</b></p> <input data-bbox="1612 1032 1654 1107" type="text"/>
---	---



N 3 4 0 2 7 A 0 2 9 3 6



18. A small submarine explores the sea-bed. The submarine has a TV camera and a powerful searchlight.

The diagram shows the path of light from the searchlight to the surface. The angle of incidence at the surface is equal to the critical angle between sea-water and air.

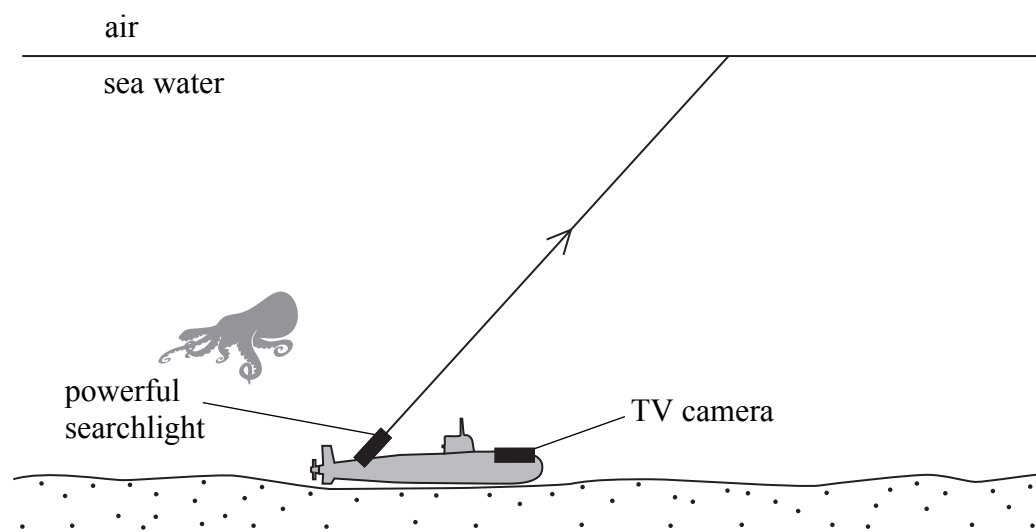

(a) On the diagram, use a ruler to continue the path of most of this light. (1)

(b) State the meaning of the term **critical angle**.  
 .....  
 ..... (1)

(c) State the equation which relates critical angle and refractive index.  
 ..... (1)

(d) (i) What happens to the light from the searchlight when it has an angle of incidence at the surface which is greater than the critical angle?  
 .....  
 ..... (1)

(ii) State the full name of the process which occurs.  
 ..... (1)



(e) Information from the TV camera is sent to a support ship by means of a cable of optical fibres.

Use a ruler to complete the diagram below to show how information is transmitted through an optical fibre.

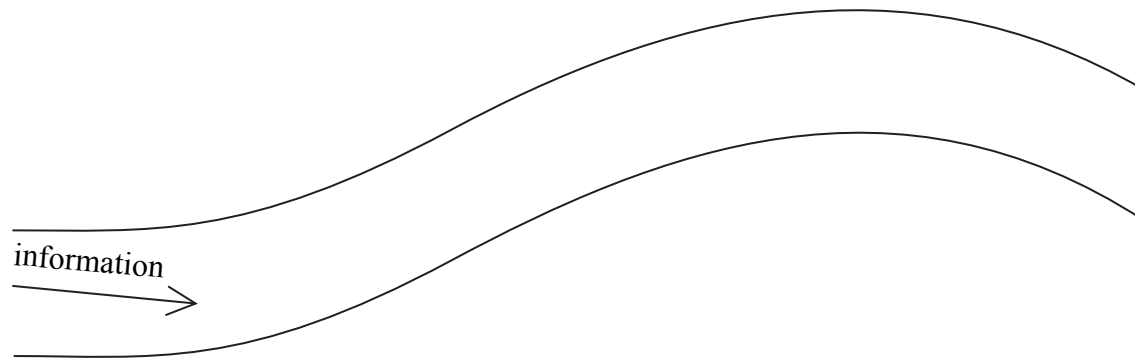

Leave blank

(2)

Q18

(Total 7 marks)



19. (a) Read the passage from a science magazine.

A century ago at the University of Manchester two research students, Hans Geiger and Ernest Marsden, carried out a series of experiments with alpha particles and gold foil. Most of the alpha particles passed through the gold foil without changing direction. However some alpha particles were slightly deflected and, very rarely, an alpha particle was deflected through an angle greater than 90 degrees. A model of an atom has been developed which accounts for their observations.

Draw a line from each observation made by Geiger and Marsden to the feature of an atom which best accounts for it.

**Observation**

**Feature of model**

Most alpha particles passed straight through the gold foil.

There are one or more electrons orbiting the centre of an atom.

Some alpha particles were slightly deflected.

Electrons each have a negative charge.

Only a small proportion of the alpha particles were deflected through an angle greater than 90 degrees.

Most of an atom does not contain any material.

The nucleus of an atom has a positive charge.

The nucleus of an atom is extremely small.

The nucleus of most atoms contains one or more neutrons.

(3)





Leave  
blank

(b) Complete the nuclear symbol for an alpha particle.



(1)

(c) Carbon-14 is unstable. It emits radiation and decays into nitrogen.

(i) Complete the balanced nuclear equation for the decay.

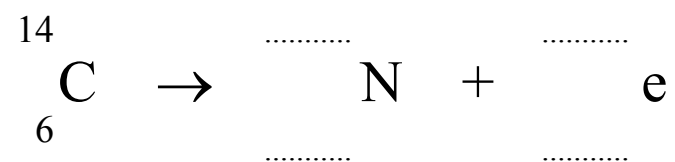

(1)

(ii) Identify, with a reason, the type of radiation emitted.

.....  
.....  
.....

(2)

Q19

(Total 7 marks)

**TOTAL FOR PAPER: 120 MARKS**

**END**



**BLANK PAGE**



**BLANK PAGE**



**BLANK PAGE**

